



TRN : 1 [REDACTED]

TAX-INVOICE

No. : IN202209-295
Date : 30/09/2022

To, [REDACTED] Dubai, UAE. Contact Person : Staff ID : Email ID : [REDACTED] TRN No : Telephone : [REDACTED]	Reg. No. : 6973 DXB-R Year : Make / Model : Mercedes / S CLASS Chassis No. : WDB1260451A526875 Odometer : 10246 Driver Customer Name : [REDACTED] Tel. : [REDACTED] Vehicle Ref ID : Estimate No./ Dt : LPO No. / Dt : Job. Ref. / Date : 102738 14/06/2022
---	---

S.No.	Description	Quantity	Unit Rate	Amount
LABOUR				
1	Overhauled Engine	1.00	2,000.00	2,000.00
2	Rear Both side Painting	1.00	750.00	750.00
			Total :	2,750.00
PARTS				
1	Oil sump gasket	1.00	90.00	90.00
2	Gasket sump	2.00	40.00	80.00
3	Crank rear oil seal	1.00	175.00	175.00
4	Engine oil filter	1.00	40.00	40.00
5	Gasket sealant	1.00	60.00	60.00
6	Engine mounting 2x75	2.00	75.00	150.00
7	Power steering oil	1.00	90.00	90.00
8	Hose intake 2x45	2.00	45.00	90.00
9	Holder intake 8x10	8.00	10.00	80.00
10	Battery	1.00	470.00	470.00
11	Head gasket 2x90	2.00	90.00	180.00
12	Valve seal set	2.00	50.00	100.00
13	Injector rubber	1.00	300.00	300.00
14	Hose intake	1.00	65.00	65.00
15	Hose intake	1.00	60.00	60.00
16	Distributor rubber	1.00	275.00	275.00
17	Spark plug	1.00	120.00	120.00



TAX-INVOICE

TRN : [REDACTED]

No. : IN202209-295

Job. Ref. : 30/09/2022

Reg. No. : 6973 DXB-R

S.No.	Description	Quantity	Unit Rate	Amount
18	Plug Wire set	1.00	230.00	230.00
19	Temperature switch	1.00	90.00	90.00
20	Bonnet Sponge	1.00	170.00	170.00
21	Auto transmission accumulator	1.00	260.00	260.00
22	Petrol distributor pump asly (used)	1.00	1,850.00	1,850.00
			Total :	5,025.00
GAS OIL				
1	consumables	1.00	100.00	100.00
2	Receiver drier	1.00	90.00	90.00
3	Engine oil and filter	1.00	300.00	300.00
			Total :	490.00
SUBLET				
1	A/c compressor repair	1.00	250.00	250.00
2	power steering hose repair	1.00	80.00	80.00
3	bush	1.00	45.00	45.00
4	A/c pipe repair	1.00	70.00	70.00
5	Machining charge for head seat and valve grinding , head spring lock opening Etc.	1.00	450.00	450.00
6	Pulley bush new making	1.00	60.00	60.00
7	Clean and service injectors with check	1.00	200.00	200.00
			Total :	1,155.00
OTHERS				
1	Petrol	1.00	870.00	870.00
			Total :	870.00
			GROSS TOTAL :	10,290.00

NOTE : Techn: Sajith

AED:TEN THOUSAND EIGHT HUNDRED FOUR AND 50 / 100

VAT (5%) : 514.50
Round Off (-) :
NET TOTAL : 10,804.50

Received vehicle to my entire satisfaction with all tools and accessories complete.

Bank Details: [REDACTED]

sanath.c

Customer [REDACTED]

Prepared By

We accepts no responsibility for payments made against this invoice unless cash stamp affixed and signed AND/OR evidenced by an official receipt.

Page 2 of 2

Five Star Auto Repairing Garage

Report on Job History From 01/01/2000 To 30/09/2022 (DETAIL)

Date : 30/09/2022

Document ID	Job Ref	Reg No	Job Type	Item/Job Description	Qty	Rate	Amount
November 2017							
[REDACTED]							
IN201711-270	83877	6973 DXB-R	(Makemodel:Mercedes / S CLASS Chassisno:WDB1260451A526875 Odometer:82025)				
Owner Name [REDACTED]							
			LABOUR				
				Front and rear brake oca			300.00
				Replaced silencer mountings			80.00
			GAS OIL				
				Full lube service include oil and filter	1.00	250.00	250.00
				A/c gas top up	1.00	120.00	120.00
			PARTS				
				Silencer rubber	2.00	60.00	120.00
						Total :	870.00
December 2017							
[REDACTED]							
IN201712-100	84086	6973 DXB-R	(Makemodel:Mercedes / S CLASS Chassisno:WDB1260451A526875 Odometer:82326)				
Owner Name [REDACTED]							
			LABOUR				
				Removed fuel distributor, replaced o rings and fuel regulator	1.00	250.00	250.00
			PARTS				
				Oil seals	2.00	45.00	90.00
				Fuel regulator	1.00	820.00	820.00

Five Star Auto Repairing Garage

Report on Job History From 01/01/2000 To 30/09/2022 (DETAIL)

Date : 30/09/2022

Document ID	Job Ref	Reg No	Job Type	Item/Job Description	Qty	Rate	Amount
						Total :	1,160.00

November 2018

[REDACTED]

IN201811-95 88667 6973 DXB-R (Makemodel:Mercedes / S CLASS Chassisno:WDB1260451A526875 Odometer:87416)

Owner Name [REDACTED]

LABOUR

Replaced wiper blade

1.00

PARTS

Wiper blade

1.00

250.00

250.00

Total :

250.00

February 2019

[REDACTED]

IN201902-207 89956 6973 DXB-R (Makemodel:Mercedes / S CLASS Chassisno:WDB1260451A526875 Odometer:435207)

Owner Name : [REDACTED]

LABOUR

Replaced battery

50.00

PARTS

Battery

1.00

700.00

700.00

Total :

750.00

Discount : 35.71

Net :

750.00

Five Star Auto Repairing Garage

Report on Job History From 01/01/2000 To 30/09/2022 (DETAIL)

Date : 30/09/2022

Document ID	Job Ref	Reg No	Job Type	Item/Job Description	Qty	Rate	Amount
May 2019							
[REDACTED]							
IN201905-75	90667	6973 DXB-R	(Makemodel:Mercedes / S CLASS Chassisno:WDB1260451A526875 Odometer:89802)				
Owner Name	[REDACTED]						
LABOUR							
				Removed trasnmission , crank rear oil seal and converter oil seal			950.00
				Removed propellor shaft replaced joint coupling and centre bearing			300.00
				Removed reapiir and refix power steering pump			350.00
				Remove repair and refix hydrolic pump			350.00
				Replaced engine oil pan hasket			150.00
				Coolingsystem flushing , replace radiator top and bottom hose and coolent filled			180.00
PARTS							
				Spark plug	8.00	35.00	280.00
				Prop shaft support	1.00	100.00	100.00
				Oil pan gasket	1.00	90.00	90.00
				Bearing shaft	1.00	100.00	100.00
				Oil seal	1.00	140.00	140.00
				Air filter	1.00	115.00	115.00
				Steering damper	1.00	145.00	145.00
				Gasket crank seal	1.00	200.00	200.00
				Gasket box kit	1.00	275.00	275.00
				Thermostat	1.00	95.00	95.00
				Radiator top hose	1.00	70.00	70.00

Five Star Auto Repairing Garage

Report on Job History From 01/01/2000 To 30/09/2022 (DETAIL)

Date : 30/09/2022

Document ID	Job Ref	Reg No	Job Type	Item/Job Description	Qty	Rate	Amount
				Radiator bottom hose	1.00	120.00	120.00
				Damping pad	2.00	65.00	130.00
				Gear Lever Bushing	2.00	30.00	60.00
				Hose clip	4.00	5.00	20.00
				JOint coupling	2.00	145.00	290.00
				Sensor, Coolant Level	1.00	40.00	40.00
				Coolant Tank	1.00	145.00	145.00
				Belt	1.00	50.00	50.00
				Belt	1.00	50.00	50.00
				Belt	1.00	50.00	50.00
				Belt	1.00	60.00	60.00
				At pan gasket	1.00	60.00	60.00
			GAS OIL				
				Full lube service	1.00	200.00	200.00
				flush and replace trasnmission oil	1.00	350.00	350.00
			SUBLET				
				Machining charges for propellor shaft check up	1.00	150.00	150.00
			OTHERS				
				Consumables	1.00	100.00	100.00
						Total :	5,765.00
						Discount : 0.71	Net : 6,052.50

August 2019

Five Star Auto Repairing Garage

Report on Job History From 01/01/2000 To 30/09/2022 (DETAIL)

Date : 30/09/2022

Document ID	Job Ref	Reg No	Job Type	Item/Job Description	Qty	Rate	Amount
IN201908-90	92205	6973 DXB-R	(Makemodel:Mercedes / S CLASS Chassisno:WDB1260451A526875 Odometer:90577)				
Owner Name :							
			LABOUR				
				Removed propeller shaft, replaced propeller shaft joint coupling, balanced and refixed			
			GAS OIL				
				A/c. gas top up	1.00	150.00	150.00
			SUBLET				
				Balancing charge	1.00	850.00	850.00
			PARTS				
				Joint coupling	2.00	495.00	990.00
				Total :			1,990.00

September 2019

IN201909-253	92773	6973 DXB-R	(Makemodel:Mercedes / S CLASS Chassisno:WDB1260451A526875 Odometer:91095)				
Owner Name :							
			LABOUR				
				Removed rear both shock absorber, made bushes and refixed	1.00	500.00	500.00
			SUBLET				
				Shock absorber repair	2.00	200.00	400.00
				Bush new making 4@100	4.00	100.00	400.00
			PARTS				

Five Star Auto Repairing Garage

Report on Job History From 01/01/2000 To 30/09/2022 (DETAIL)

Date : 30/09/2022

Document ID	Job Ref	Reg No	Job Type	Item/Job Description	Qty	Rate	Amount
				Hydraulic oil	1.00	80.00	80.00
						Total :	1,380.00

October 2019

██████████

IN201910-109 93039 6973 DXB-R (Makemodel:Mercedes / S CLASS Chassisno:WDB1260451A526875 Odometer:91397)
 Owner Name ██████████

LABOUR

Replaced rear Lhs suspension Accumulator 1.00

PARTS

Accumulator 1.00 935.00 935.00

GAS OIL

Power steering fluid 1.00 60.00 60.00

Total : 995.00

March 2020

OMAR ABBAS

IN202003-13 94629 6973 DXB-R (Makemodel:Mercedes / S CLASS Chassisno:WDB1260451A526875 Odometer:92896)
 Owner Name ██████████

LABOUR

Removed transmission assy , replaced crank rear oil seal
 and converter oil seal 1,300.00

Five Star Auto Repairing Garage

Report on Job History From 01/01/2000 To 30/09/2022 (DETAIL)

Date : 30/09/2022

Document ID	Job Ref	Reg No	Job Type	Item/Job Description	Qty	Rate	Amount
				Replaced engine oil pan gasket			700.00
				Replaced valve cover gasket			400.00
				Replaced trasnmission oil pan gasket			200.00
				Replaced radiator assy			250.00
			GAS OIL				
				Full lube service	1.00	300.00	300.00
			SUBLET				
				Steam wash	1.00	150.00	150.00
			PARTS				
				Gear converter oil seal	1.00	105.00	105.00
				Gasket	1.00	45.00	45.00
				Gasket	1.00	45.00	45.00
				AT Gakset	1.00	50.00	50.00
				Radiator top hose	1.00	65.00	65.00
				Thermostat with gasket	1.00	80.00	80.00
				AT Filter	1.00	65.00	65.00
				Oil pan gasket	1.00	135.00	135.00
				Oil Pan Gasket	1.00	135.00	135.00
				Oil Seal	1.00	145.00	145.00
				Radiator assy	1.00	930.00	930.00
				Gasket silicone	1.00	120.00	120.00
				Connetor o ring	1.00	45.00	45.00
				Hose clips	3.00	5.00	15.00
			GAS OIL				

Five Star Auto Repairing Garage

Report on Job History From 01/01/2000 To 30/09/2022 (DETAIL)

Date : 30/09/2022

Document ID	Job Ref	Reg No	Job Type	Item/Job Description	Qty	Rate	Amount
				Coolant	4.00	30.00	120.00
				ATF oil	9.00	45.00	405.00
			OTHERS				
				Consumables	1.00	80.00	80.00
						Total :	5,885.00

██████████

IN202003-225 94979 6973 DXB-R (Makemodel:Mercedes / S CLASS Chassisno:WDB1260451A526875 Odometer:93420)
 Owner Name ██████████

PARTS

Transmission oil dipstick	1.00	180.95	180.95
		Total :	180.95

March 2021

██████████

IN202103-13 98003 6973 DXB-R (Makemodel:Mercedes / S CLASS Chassisno:WDB1260451A526875 Odometer:97634)
 Owner Name ██████████

LABOUR

Lowering front rh suspension			350.00
Front rh hub servicing and replaced grease cap set			200.00

SUBLET

Tyres	4.00	300.00	1,200.00
-------	------	--------	----------

Five Star Auto Repairing Garage

Report on Job History From 01/01/2000 To 30/09/2022 (DETAIL)

Date : 30/09/2022

Document ID	Job Ref	Reg No	Job Type	Item/Job Description	Qty	Rate	Amount
			PARTS				
				Hub grease cap	1.00	120.00	120.00
			OTHERS				
				Consumables	1.00	30.00	30.00
			SUBLET				
				Wheel allignment	1.00	300.00	300.00
Total :							2,200.00

██████████

IN202103-158 98192 6973 DXB-R (Makemodel:Mercedes / S CLASS Chassisno:WDB1260451A526875 Odometer:)
 Owner Name : ██████████

PARTS

Wheel cap 2@50 2.00 50.00 100.00

Total : 100.00

Discount : 4.76 Net : 100.00

██████████

IN202103-37 98058 6973 DXB-R (Makemodel:Mercedes / S CLASS Chassisno:WDB1260451A526875 Odometer:97800)
 Owner Name : ██████████

LABOUR

Replaced front Rhs wheel bearing 1.00

PARTS

Wheel bearing (130+120) 1.00 250.00 250.00

Five Star Auto Repairing Garage

Report on Job History From 01/01/2000 To 30/09/2022 (DETAIL)

Date : 30/09/2022

Document ID	Job Ref	Reg No	Job Type	Item/Job Description	Qty	Rate	Amount	
							Total :	250.00

June 2021

[REDACTED]

IN202106-71 98727 6973 DXB-R (Makemodel:Mercedes / S CLASS Chassisno:WDB1260451A526875 Odometer:98658)

Owner Name [REDACTED]

LABOUR

Overhauling steering box for oil leakage			850.00
Replaced rear lh wheel bearing			250.00
Removed and replaced ignition key set			450.00

PARTS

Ignition key	1.00	120.00	120.00
Cover	1.00	100.00	100.00
Ignition coil	1.00	155.00	155.00
Steering box kit	1.00	410.00	410.00
Wheel bearing	1.00	250.00	250.00

GAS OIL

Power steering oil	1.00	40.00	40.00
Hydraulic oil	1.00	45.00	45.00

SUBLET

Repaired key barrel	1.00	350.00	350.00
---------------------	------	--------	--------

OTHERS

Petrol	1.00	80.00	80.00
Consumable	1.00	60.00	60.00

Five Star Auto Repairing Garage

Report on Job History From 01/01/2000 To 30/09/2022 (DETAIL)

Date : 30/09/2022

Document ID	Job Ref	Reg No	Job Type	Item/Job Description	Qty	Rate	Amount
						Total :	3,160.00

October 2021

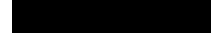

IN202110-74 99512 6973 DXB-R (Makemodel:Mercedes / S CLASS Chassisno:WDB1260451A526875 Odometer:99643)
 Owner Name :OMAR ABBAS

LABOUR

Replaced fuel guage 250.00

PARTS

Fuel guage 1.00 970.00 970.00

Rad cap 1.00 50.00 50.00

SUBLET

Towing charge 1.00 130.00 130.00

Total : 1,400.00

1990 MERCEDES-BENZ 560 SEC (126.045)



LastVIN.com

VIN Decoder for Mercedes-Benz

General Data

FIN WDB1260451A526875
Model 560 SEC
Engine 117968 12 081624
Transmission 722350 03 331453
Order Number 0 0 839 50176
Order Location JAPAN
Interior LEATHER - BEIGE (265)
Paint 1 SMOKE SILVER METALLIC (702U)
Approx. Build Date 1990-01

Code Description

253 RADIO MB - EXQUISIT - JAPAN
442 AIRBAG IN STEERING WHEEL
498 VERSION FOR JAPAN
524 PAINTWORK - PRESERVATION
581 AUTOMATIC CLIMATE CONTROL
592 HEAT-INSULATING GLASS, ALL-AROUND, HEATED REAR WINDOW PANE, BAND FILTER
613 HEADLAMP LEFT-HAND TRAFFIC
800 CHANGE OF MODEL YEAR, THE LAST FIGURE SHOWING THE NEW MODEL YEAR
873 SEAT HEATER FOR LEFT AND RIGHT FRONT SEATS

1990 MERCEDES BENZ S CLASS 560SEC

Report generated on 2022-11-09

VEHICLE DETAILS

Data Sources	USS Kyushu
Data Recorded dates	2011-12-24
Lot numbers	11045
Chassis ID/VIN	WDB1260451A526875
Make	MERCEDES BENZ
Model	S CLASS
Mileage	159,189 KM
Engine CC	5600 (5,6 L)
Reg. Date	1990-3
Grade/Trim	560SEC
Last Japanese inspection expiry date	N/A
Equipment	AAC
Transmission	FAT
Start price 2011-12-24	████████
Finish price 2011-12-24	████████
Color	GOLD
Condition	3
Sales Status	Sold

GRADE

3

AUTOCHECK GRADING

Poor condition

The Autocheck grading scheme is based on standard Japanese auction grading system. it let's you compare similar vehicles with ease.

Auction grade

3 Poor condition

Accident / Repair

No problem reported

Mileage report

No problem reported

Use history

Private Car 自家用

Stolen check

No stolen status

AUTOCHECK FACTS
Auction grade

Poor condition / noticeable dents & damage / rust / past repair

Odometer check

Good mileage report and No any kind of Odometer tampering history reported

NOTE: This Autocheck Vehicle History Report is based only on Information supplied to Autocheck Japan. and available as of 2022-11-09 -22:40:13. Other information about this vehicle, including problems, may not have been reported to Autocheck Japan. Use this report as one important tool, along with a vehicle inspection and test drive, to make a better decision about your next Japanese used car.

✔ ACCIDENT / REPAIR HISTORY (JAPAN)

Type of record	Reported event	Reported date	Source	Details	Airbag
Collision	✔ Not reported				
Malfunction	✔ Not reported				
Theft	✔ Not reported				
Fire damage	✔ Not reported				
Water damage	✔ Not reported				
Hail damage	✔ Not reported				

REPORTED ODOMETER HISTORY

Reported date	Kilometres	Source
2011-12-24	159,189 km	USS Kyushu

✔ USE HISTORY (JAPAN)

Use in the contaminated regions ⁴	Radioactive contamination test fail ⁵	Commercial use
Not reported	Not reported	Not reported

CONDITION SHEETS & PHOTOS

Date : 2011-12-24 Source : USS Kyushu Lot No : 11045

※必ず油性ボールペンをご使用下さい。水性ボールペンは使用できません。

No. 11045	車歴 (自家用以外は記入) 排気量 5540 cc		型式 E-126045		評価点 3
	初度登録年月 2/3月	車名 バンツ	形式+7数 271	グレード 560 SEC	
車検	年	月	シフト FAT	装備品 SR 6R 6AW PS PW カワ TV ナビ エアB	内装 補修評価 C
走行 159189 Km マイル	外色 ゴールド	色番 色目 カラー貼	冷房 AAC	*純正品に限り該当に○をつけて下さい。 セールスポイント 買取車 左ハンドル リヤスポイラー ETC	
燃料 ガソリン・軽油・()	燃入区別 ディーラー・並行	ハンドル 左・右	新車整備手帳 (保証書付) 有・無	*書類と一緒に保管下さい。	
リサイクル預託金 16340 円 預託済み	名義変更期限 月 日	車庫定員 4人	登録No.	車台No. WDB126045-1A526875	
◎注意事項 (郵送・不具合箇所および状態等)			預託額 ↑	シリアルNo.	

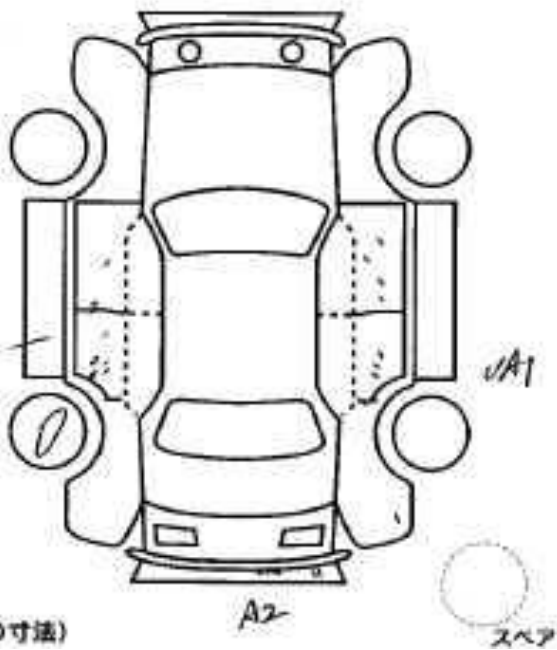

◎検査員報告

右R/W不良
天張り等 } 汚水
シート巾
木目干渉
木目上面カチ干渉
ドア部一部不良
白煙

長さ 493 cm 幅 183 cm 高さ 141 cm ← (車検証上の寸法)

CONDITION CHECK SHEET ENGLISH TRANSLATION

Date : 2011-12-24 Source : USS Kyushu Lot No : 11045

Auction No.	Vehicle Use	Displacement	Grade	Grade	
11045	Private	5600 cc	560SEC	3	
	Japan Y/M	Make/model	Model code	Door Style	Interior
	1990-3	MERCEDES BENZ	E-126045	2CP	C

Current Inspection (Year/month)		
-		
Mileage in Kms		Symbol
159,189 KM		
original color	change color	color no:
GOLD		
Fuel		Interior color
Gasoline		
Seats	Drive type	Drive
4		LHD
Notice		

Transmission
FAT
Air condition
AAC
Recycling deposit
¥16,340
Registration number
-
Chassis number
WDB1260451A526875

Sun roof	alloy wheel	power steering	power window
-	-	✓	✓
Leather	TV/NAVI	ABS	Airbag
-	-	-	✓
Sales point			
The car was in the private using Left hand drive ETC Rear spoiler			

Inspector Report

Body - scratches, dents
 Top/upper part of car body - scratches
 Rear right power window - faulty
 Wheels - scratches
 Driver power seat - partially faulty
 Ceiling cover - floated, soiled
 Seats - folds, dirt
 White smoke

- A1 Small scratch
- A2 Scratch
- A3 Large scratch
- U1 Small dent
- U2 Medium dent
- F Paint peeling off
- P Paint Faded, damaged, burned mark
- D1 Small crack in glass
- W2 Repair Mark/Wave
- W3 Obvious Repair Mark/Wave (needs to be repainted)
- XX Part, panel or Item Replaced

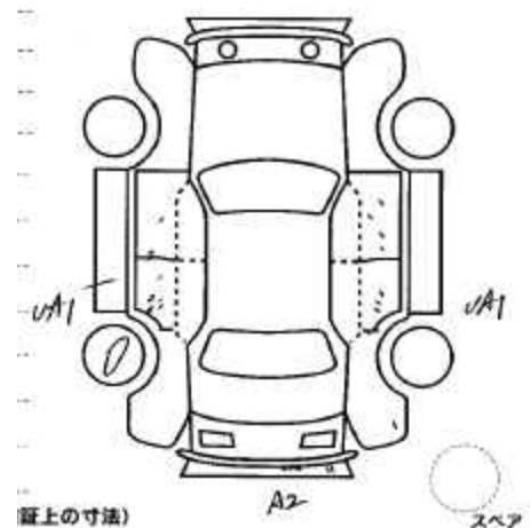

Length	Width	Height
493	183	141

*Please proceed to the next page to see the full auction list explanation.

AUCTION LIST EXPLANATION

A1 Small Scratch	S1 Rust
A2 Scratch	S2 Heavy Rust
A3 Big Scratch	U1 Small Dent
B Dent with scratch	U2 Dent
B1 Distortion on (radiator) core support or back panel (approximately size of a thumb)	U3 Big Dent
B2 Big Distortion on (radiator) core support or back panel	Y1 Small Hole or Crack
B1-B4 Large dents	Y2 Hole or Crack
C1 Corrosion	Y3 Big Hole or Crack
C2 Heavy Corrosion	X1 Small Crack on Windshield (approximately 1cm)
AU2 Dent and Scratch (Medium).	R Repaired Crack on Windshield
E1 Few Dimples	RX Repaired Crack on Windshield (needs to be replaced)
E2 Several Dimples	X Needs to be replaced or crack on glass
E3 Many Dimples	XX Replaced
G Stone chip in glass	W1 Repair Mark/Wave (hardly detectable)
H Paint faded or (Thumb size hole from rust, corrosion or rotting)	W2 Repair Mark/Wave
P Paint damaged marked	W3 Obvious Repair Mark/Wave (needs to be repainted)

AUCTION GRADE EXPLANATION

6 / S New car	0 Repaired
5 Used but appears as new	R Repaired (History of being repaired, parts replaced, no quality guarantee, buy at your risk, could be big damages, frame bent possibility.)
4.5 Very clean with only minor pin dents & scratches	RA Accident repaired, been in crash, parts replaced, generally small damages.
4 Good condition with normal wear & tear	*** Ungraded (existing fault / damage)
3.5 Numerous condition faults / possible minor repair	A - D Body / interior condition (A – as new , B – very clean , C – average , D – poor)
3 Poor condition / noticeable dents & damage / rust / past repair	E – The car is in bad shape. Rust, corrosion and exterior breakdowns are plenty.
2 Very poor condition / water damaged	
1 Modified (usually performance parts)	



Verified source (USS Kyushu 2011-12-24)



Verified source (USS Kyushu 2011-12-24)

GLOSSARY

1 Chassis number: a unique identification number of the vehicle in Japan (same as VIN in the USA or Europe)

2 Safety grade: Determining the overall collision safety performance evaluation – For the driver's seat, the results of the full-wrap frontal collision test, offset frontal collision test, and side collision test are added together and evaluated to 6 different levels. For the Frontal passenger's seat, the results of the full-wrap frontal collision test and the side collision test (results for the driver's or the front passenger's seat are used) are added together and evaluated to 6 different levels.

3 Title information:

Registered – qualified for driving in Japan

Deregistered Temporarily – not qualified for driving in Japan, usually a temporary title during the ownership change

Deregistered Completely – not qualified for driving in Japan, the vehicle is determined to be scrapped

Deregistered to Export – not qualified for driving in Japan, the vehicle is determined to be exported

4 Use in the contaminated regions: The Fukushima Daiichi nuclear disaster was a catastrophic failure at the Fukushima I Nuclear Power Plant on 11 March 2011, resulting in a meltdown of three of the plant's six nuclear reactors. As a result, some areas in the following prefectures were contaminated: Fukushima, Miyagi, Ibaraki, Tochigi.

5 Radioactive contamination test: radioactive contamination inspection that was started in July 2011 as a preventive measure for exporting contaminated vehicles from Japan. The inspection is being conducted since in all sea ports of Japan under the supervision of The Japan Harbor Transportation Association (JHTA).

MLIT – Ministry of Land, Infrastructure, Transport and Tourism.

Odometer Reading Authenticity

\$ Odometer replacement made with proof of mileage, old mileage has to be added on (kilometers in Japan)

***** Odometer clocked or re-wound

Unknown mileage

AUTOCHECK.JP DEPENDS ON ITS SOURCES FOR THE ACCURACY AND RELIABILITY OF ITS INFORMATION. THEREFORE, NO RESPONSIBILITY IS ASSUMED BY AUTOCHECK.JP OR ITS AGENTS FOR ERRORS OR OMISSIONS IN THIS REPORT. AUTOCHECK.JP FURTHER EXPRESSLY DISCLAIMS ALL WARRANTIES, EXPRESS OR IMPLIED, INCLUDING ANY IMPLIED WARRANTIES OF MERCHANTABILITY OR FITNESS FOR A PARTICULAR PURPOSE.